

INSIDE

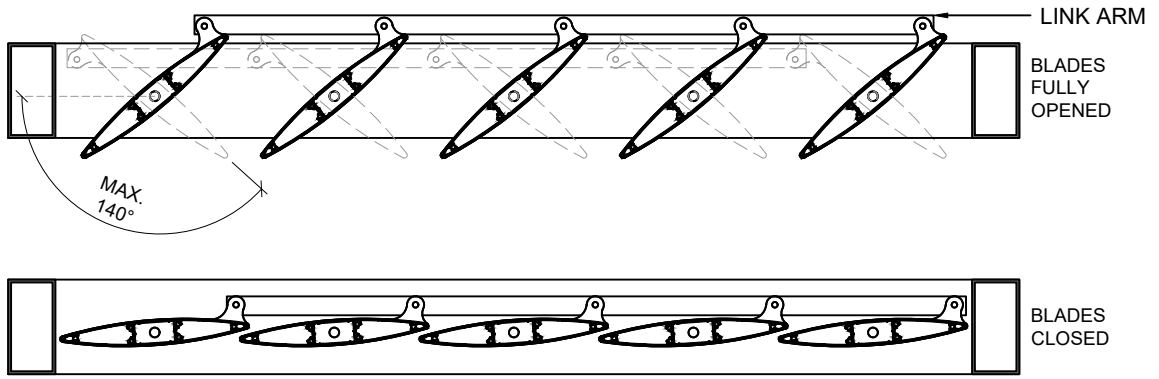

PLAN VIEW  
(BLADES MOUNTED VERTICALLY)  
(FINS CAN BE IN OPPOSITE DIRECTION AS SHOWN)

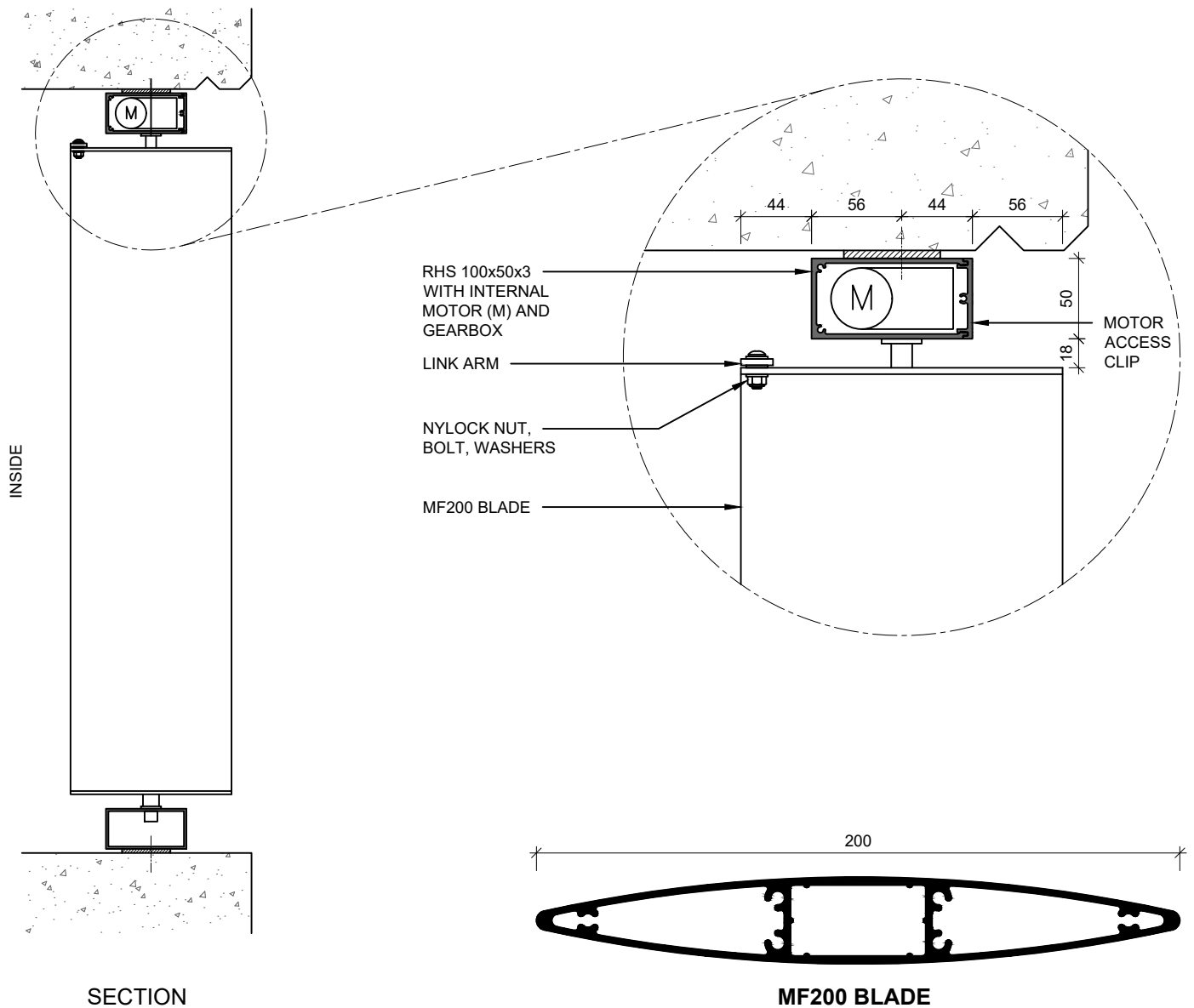

**MF200 MAXIM ELLIPTICAL FINS  
MOTORISED - REVEAL FIX**

FINS CAN ALSO BE MOUNTED HORIZONTALLY  
ALSO AVAILABLE FOR 150, 300, 400

[www.maximlouvres.com.au](http://www.maximlouvres.com.au)

**maxim**®  
louvres

DWG No.: MF200 Motorised - RF  
DWG Date: 19.02.2024